

Multiflux™

Overcoming the challenge of reliable multi-way fluidic connections



White paper	page
Multi-way fluidic connections	2
Multiflux™	2
Using Multiflux™	4
Conclusion	8



Microfluidic connections

If you are struggling to create fast and reliable microfluidic connections, Multiflux™ may be the solution you are looking for.

Systems for manipulation, analysis and control of small amounts of fluids are becoming increasingly sophisticated. In addition, there is an increasing trend for these systems to be designed at smaller and smaller scales into the microfluidic domain.

Traditional connectors only allow a connection of one fluid tube at a time.

In the field of electrical connections we are all used to robust and easy to use multi-way connectors. However, most fluidic connectors only allow the connection of one fluid tube at a time. Furthermore, connecting microfluidic devices to macro-scale systems presents many challenges.

If these are not addressed well, the benefits of working within the microfluidic regime may be compromised, with an excessive amount of research time being spent on time consuming assembly and resolving leaks.

When working with microfluidic connections, engineers and scientists are facing the following challenges:

- **Easy to use:** time-efficient assembly, no extra tools required;
- **Quick solution:** find a solution that allows to make and break reliable and leakfree connections in seconds;
- **Multi-way connections:** interconnection of many tubes at once in a high-density format;
- **Simple and robust:** find a solution that allows tube-to-chip, tube-to-tube and tube-to-manifold connections;
- **Compact and reusable** solution.

A lot of research time is spent on time-consuming assemblies and resolving leaks.

All of these challenges have now been solved with Multiflux™, Dolomite's industry-leading range of microfluidic connectors and interfaces.



Multiflux™ is Dolomite's solution for anyone working with microfluidic systems.

Create fast and reliable multi-way fluidic connections with Multiflux™.

This unique range of microfluidic connectors and interfaces enables the fast and easy interconnection between a range of fluidic systems and / or bundles of tubing without disruptions to the fluid flow.

Designed to be easily integrated into any microfluidic system, Multiflux™ helps users to solve their interconnection challenges facilitating tube-to-chip, tube-to-manifold, chip-to-chip as well as tube-to-tube connections.

This white paper illustrates how Multiflux™ Connectors and Interfaces benefit a number of different applications by creating fast and reliable multi-way fluidic connections between various fluidic modules.

The applications include:

1. Fluid dispensing robot heads
2. Tube-to-tube connections
3. Valve manifolds
4. Gas Chromatography chips

Using Multiflux™

1. Fluid dispensing robot heads

Fluid dispensing robots often have multiple nozzles (cannulas) to allow simultaneous fluid dispensing to multiple locations on a wellplate.

Multiflux™ Linear Connector provides a compact and reliable solution for connecting between a set of tubes and a robot head, as shown below:

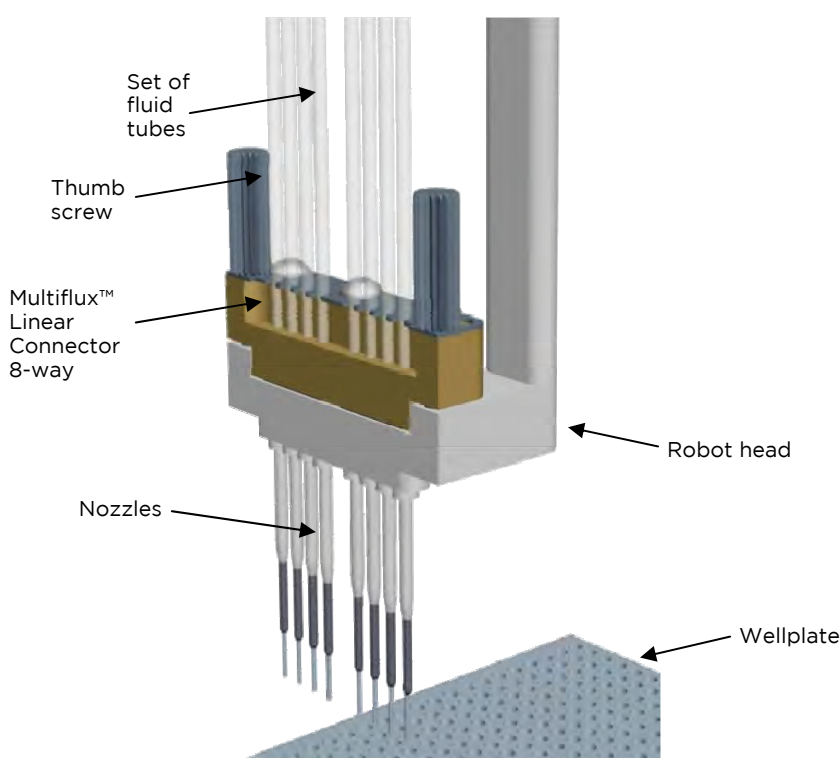

The Linear Connector 8-way engages directly with the robot head. By tightening down the two thumb screws a seal is made between the fluid tubes and the nozzles on the robot head. The perfluoroelastomer seal on the Linear Connector 8-way has very low dead volume and is chemically inert making it suitable for a number of different applications.

The Multiflux™ connector can also be customized to match the pitch between nozzles and match the number of nozzles required. The minimum pitch that is possible with a Multiflux™ Linear Connector is 2-times the tube diameter which is significantly less than the minimum pitch that is possible with threaded nuts and ferrules.

Using Multiflux™

2. Tube-to-tube connections

Traditional solutions for tube-to-tube connections consist of unions, fittings and ferrules which are not only difficult to assemble but also bring with them the problem of creating a leakfree connection when using multiple unions.

Multiflux™ solves this problem by providing a flexible and time-efficient solution. The Multiflux™ In-line Interfaces allow in-line connection and disconnection of up to 24 tubes in one go. By mounting the interfaces one above the other it is possible to build up a connector array providing reliable connections between hundreds of fluid tubes.

In the example shown below a stack of 6 Multiflux™ Interfaces are assembled allowing 144 fluid connections to be made across an area of 55mm x 50mm. The density of fluid connections per unit area is much higher than what is possible using threaded fittings and ferrules.

The main application areas for this type of connector are parallel sample processing and analysis, for example DNA analysis and water sample analysis.

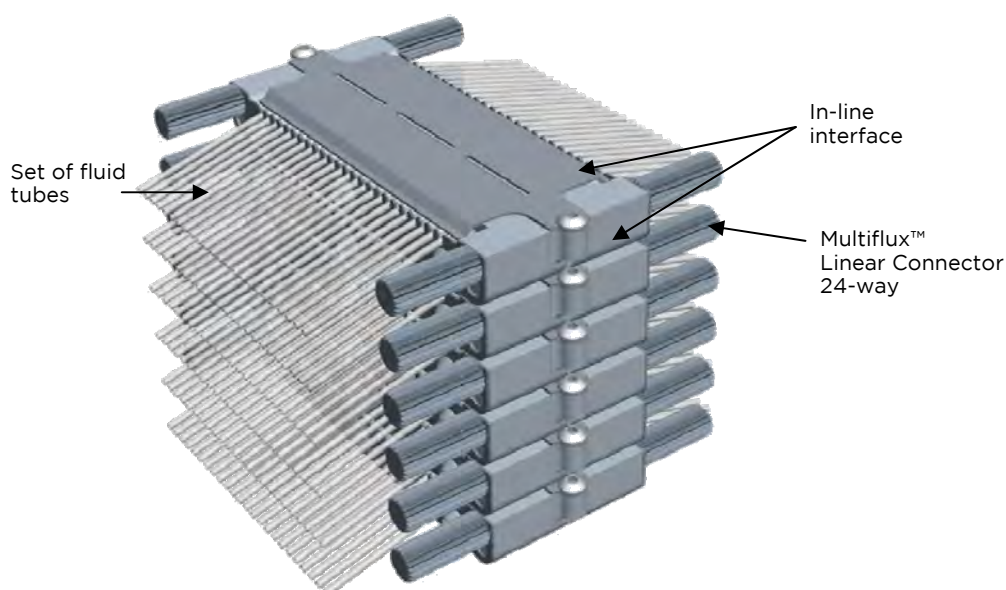

Using Multiflux™

3. Valve manifolds

Valve manifolds are used in a number of applications where liquids or gases need to be routed from one input to multiple outputs or vice versa. Solenoid valves are typically mounted directly onto the manifold and fluid tubes are connected using an array of threaded fittings and ferrules. These connector solutions take up a lot of space and involve a time consuming set-up and problem of sealing.

The benefits of using Multiflux™ Linear Connectors over threaded fittings and ferrules include fast connection and disconnection of a group of tubes and/or individual tubes, reduced cost per connection as well as reduced pitch between tubes which allows higher density connections and smaller manifolds.

An example of a valve manifold connection is shown below:

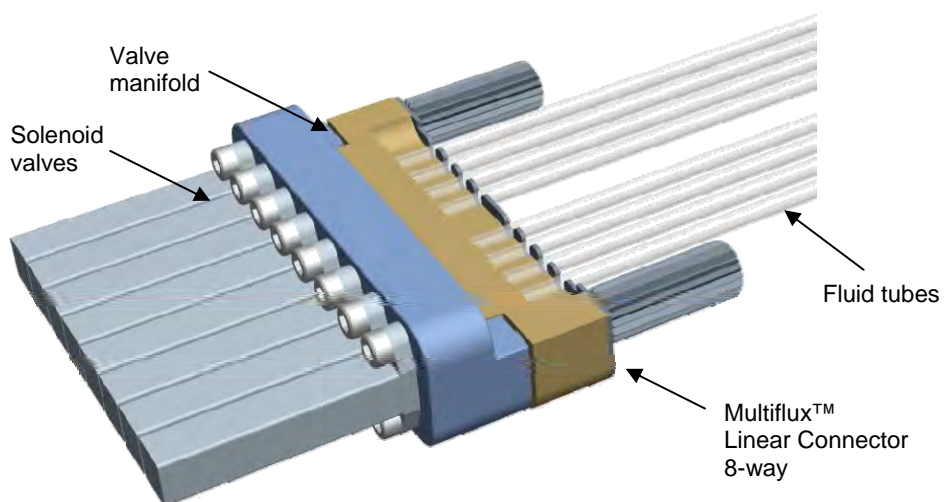

Using Multiflux™

4. Connections to Gas Chromatography chips

Gas Chromatography (GC) is a highly sensitive chemical analysis technique with a broad range of applications. However, existing commercial GC systems are generally quite bulky and fragile and miniaturization could significantly broaden the range of applications.

Currently, there are not many reliable solutions available to connect tubes to GC chips. Common fittings include the connection of fluid tubes to the chip via a “glue-on” technique which is very time-consuming and requires skill to achieve good alignment and reliable connection.

Multiflux™ solves this problem by providing a reliable and compact solution which takes up less surface area on the chip than traditional solutions. Easy to use, the Multiflux™ Linear Connectors can connect and accurately align up to 24 fluid tubes at once.

The following example shows the Multiflux™ Linear Connector 4-way which connects 4 PEEK tubes to the top surface of a glass microfluidic chip.

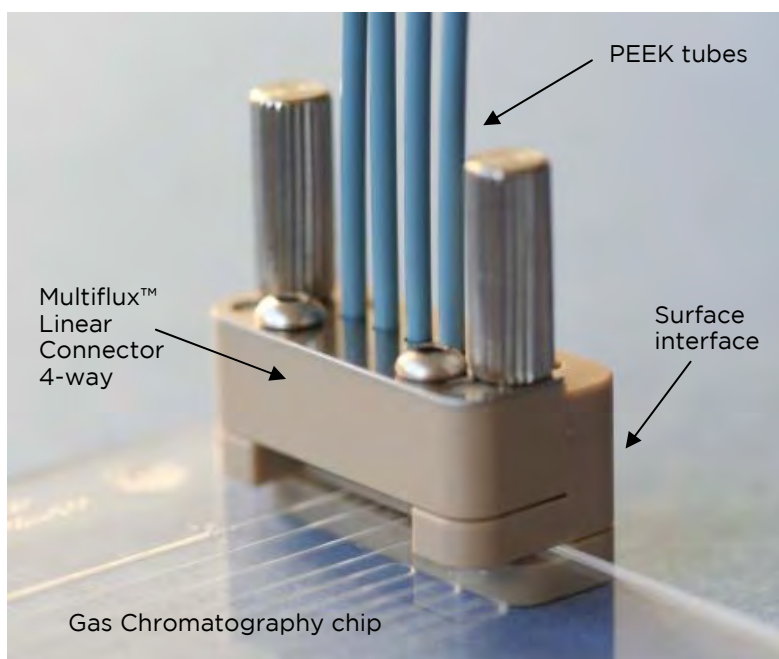



The Multiflux™ Connector engages with the surface interface and creates a fluidic seal as well as perfect alignment between the PEEK tubes and fluid holes on the chip. Connection and disconnection of the Multiflux™ Connector and the PEEK tubes can be carried out quickly and easily, without the need for tools.

Conclusion

Multiflux™ provides a compact and fast solution to anyone working with microfluidic systems and multi-way fluidic connections by offering the following advantages:

- **Quick and easy to use:** Multiflux™ allows users to make and break reliable and leakfree connections in seconds, no extra tools required;
- **Multi-way connections:** Multiflux™ facilitates interconnection of many tubes at once in a high-density format;
- **Flexible solution:** Multiflux™ Connectors can be position on the edge or top surface of a chip. They also allow chip-to-chip and tube-to-tube connections;
- **Reusable:** all Multiflux™ Connectors and Interfaces can be used over and over again with multiple chips;
- **Chemical compatibility:** all Multiflux™ components are resistant to a wide range of chemicals including organic solvents, acids and bases.

For more information visit the Dolomite website
www.dolomite-microfluidics.com/products/multiflux.



The Dolomite Centre Ltd.

Unit 1, Anglian Business Park, Royston,
Hertfordshire, SG8 5TW, United Kingdom

T: +44 (0)1763 242491

F: +44 (0)1763 246125

E: info@dolomite-microfluidics.com

W: www.dolomite-microfluidics.com

Dolomite Microfluidics

29 Albion Place
Charlestown, MA 02129

F: 617 848 1211

F: 617 500 0136

E: salesus@dolomite-microfluidics.com

W: www.dolomite-microfluidics.com